

Tata Steel Speciality Steels, Stocksbridge Collection Plan

Loading:

Monday – Saturday 0600-0600

POST CODE: S36 1EA

PPE Requirements:



Additional Information:



Loading/Securing:

Stand in green area during loading

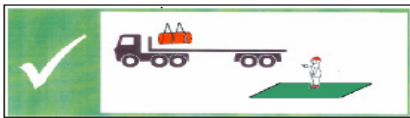

DOORS MUST BE KEPT CLOSED WHEN DRIVING ON SITE

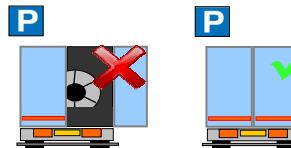

Straps LC 2000 daN



NO CUTS

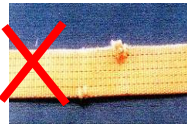

NO KNOTS



NOT WORN

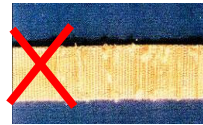

Min x 12

Min x 24

3. Overview of tie-down restraint system

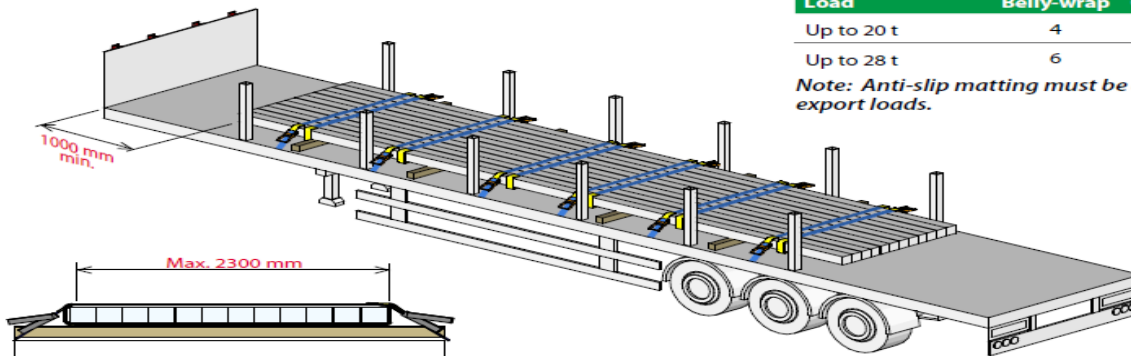

Note: Tensioners applied to both sides of the belly-wrap.

Table 1: Minimum number of straps

Load	Belly-wrap	Over-the-top
Up to 20 t	4	0
Up to 28 t	6	0

Note: Anti-slip matting must be applied to all export loads.

This Load Restraint Guideline has been designed to meet the forces for road transport stipulated in EN 12195-1:2010 and VDI 2700. The restraint system has been validated by inclination tests as per EN 12195-1:2010 Annex D.2, and emergency braking dynamic tests.

LOADS MUST BE SECURED IN THE LOADING BAY – PLEASE HAVE STRAPS READY BEFORE ENTERING THE BAY